

SERIES 450 STORMWATER PITS AND GRATES

Products covered in this spec sheet are as listed below:

Product	Code	Class	Weight	Overall Size	Depth	Category
Series 450 Shallow Pit	80034		5.6kg	L: 565 x W: 565mm	383mm	Pit
Series 450 Deep Pit	80001		8.0kg	L: 565 x W: 565mm	510mm	Pit
Series 450 Riser	80035		4.8kg	L: 565 x W: 565mm	240mm	Pit
Galvanised Grate	21041	A	14.0kg	L: 541 x W: 541mm	50mm	Grate
Polymer Cover	84921	A	2.3kg	L: 541 x W: 541mm	25mm	Grate
Galvanised Checker Plate	21050	A	13.0kg	L: 545 x W: 545mm	53mm	Grate
Series 450S Stormwater Pit with Galvanised Grate	80073	B	16.2kg	L: 565 x W: 565mm	325mm	Pit & Grate
Series 450D Stormwater Pit with Galvanised Grate	80075	B	17.8kg	L: 565 x W: 565mm	500mm	Pit & Grate

Material

Pits: Recycled polypropylene
 Grates: Galvanised steel or 316 stainless steel
 Covers: Polymer, galvanised steel or reinforced concrete

Suitable Applications



LOW-HIGH RAINFALL



OUTDOOR AREAS

Warranty

Polymer Components 5 Years

Metal Components 1 Years

Product Drawing

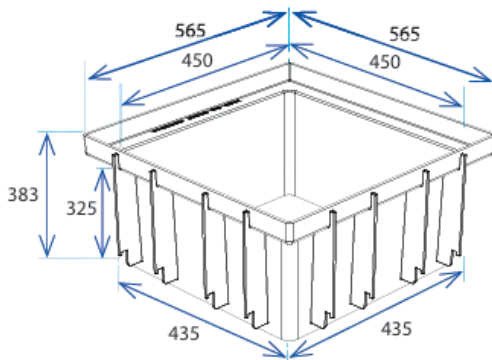

SERIES 450 SHALLOW STORMWATER PIT

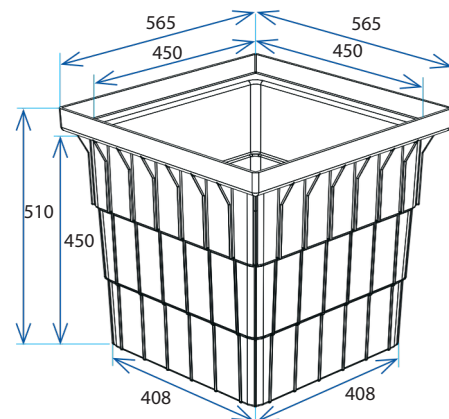

SERIES 450 DEEP STORMWATER PIT

Disclaimer: All measurement are in millimetres and are solely for reference purposes. Colours have been reproduced with as much accuracy as possible. Any changes resulting from technical advance of design or colour may be made without prior notice. Further information on warranties is available at www.everhard.com.au

Product Drawing

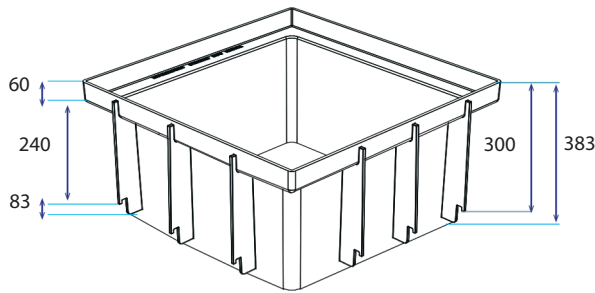

SERIES 450 RISER

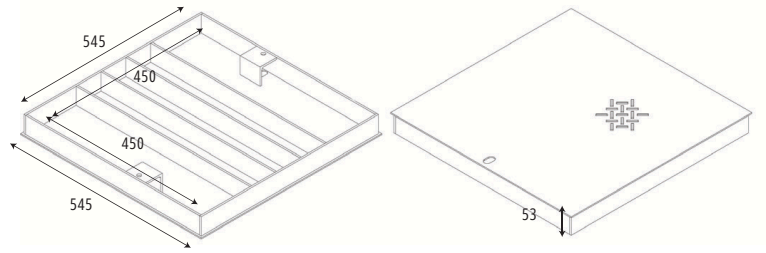

SERIES 450 GALVANISED CHECKER PLATE COVER

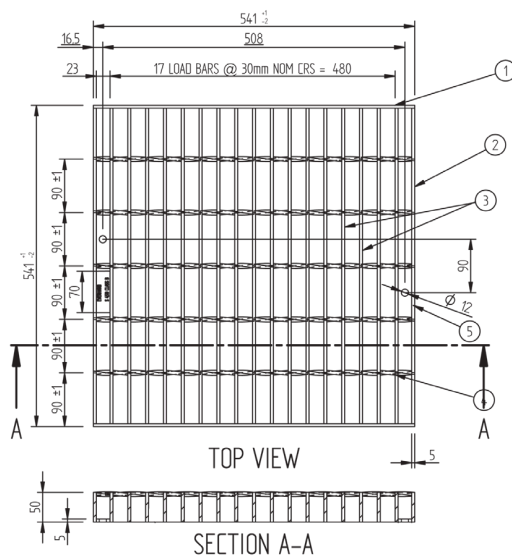
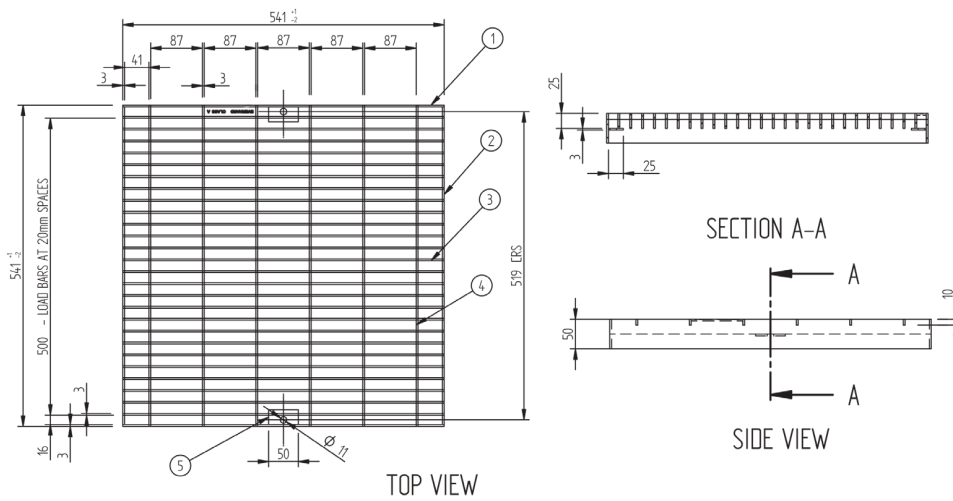

21041 GALVANISED GRATE