

SERIES 300 STORMWATER PITS AND GRATES

Products covered in this spec sheet are as listed below:

Product	Code	Class	Weight (kg)	Overall Size	Depth	Category
Series 300S Stormwater Pit with Galvanised Grate	80071	A	5.2	L: 355 x W: 355mm	360mm	Pit & Grate
Series 300D Stormwater Pit with Galvanised Grate	80072	A	5.9	L: 357 x W: 357mm	425mm	Pit & Grate
Series 300 Stormwater Pit Leaf Basket	84042		0.3	L: 290 x W: 290mm	106mm	Accessory
Series 300 Stormwater Pit Riser	84221		1	L: 357 x W: 357mm	198mm	Accessory
Series 300S Stormwater Pit Case	84811		1.8	L: 357 x W: 357mm	326mm	Pit
Series 300D Stormwater Pit Case	84816		2.3	L: 357 x W: 357mm	452mm	Pit
Series 300 Galvanised Steel Grate	84827	A	4	L: 345 x W: 345mm	25mm	Grate
Series 300 Polymer Cover	84953		0.8	L: 360 x W: 360mm	55mm	Cover
Series 300 Aluminium Grate	84845	A	1	L: 300 x W: 300mm	22mm	Grate
Series 300S Stormwater Pit with Aluminium Grate	84938	A	2.8	L: 357 x W: 357mm	326mm	Pit & Grate
Series 300D Stormwater Pit with Aluminium Grate	84939	A	3.3	L: 357 x W: 357mm	452mm	Pit & Grate

Material

Pits: Recycled UV stabilised polymer
 Grates: Galvanised steel or aluminium
 Covers: Recycled UV stabilised polymer

Suitable Applications



LOW-HIGH RAINFALL



OUTDOOR AREAS

Warranty

Polymer Components 5 Years

Metal Components 1 Years

Product Drawing

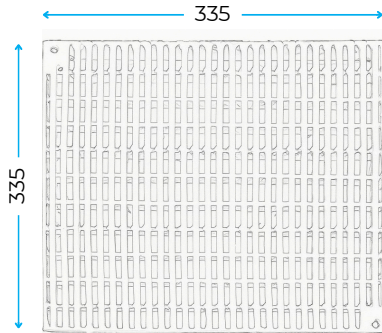

SERIES 300 GALVANISED GRATE

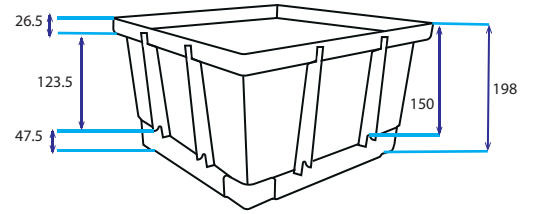

SERIES 300 STORMWATER PIT RISER

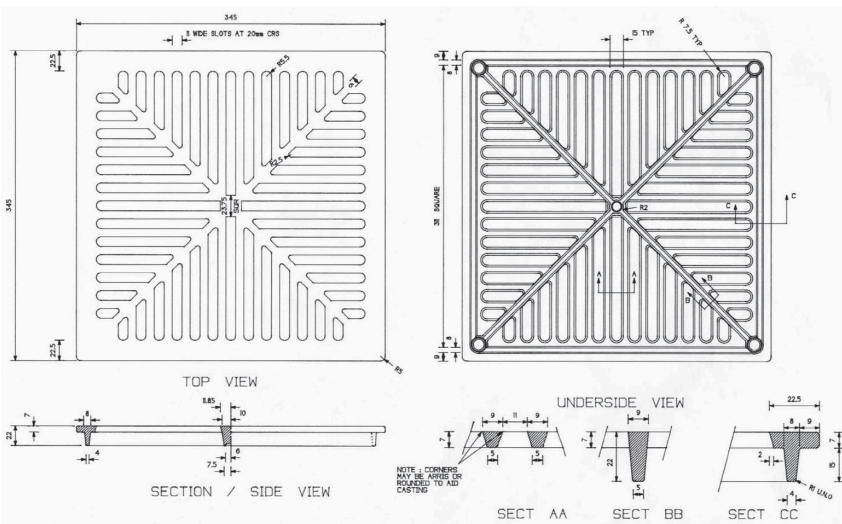

SERIES 300 ALUMINIUM GRATE

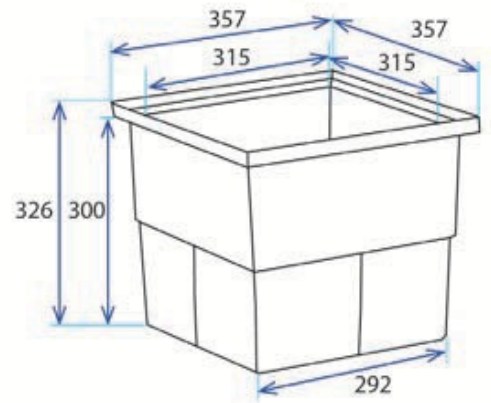

SERIES 300S STORMWATER PIT CASE

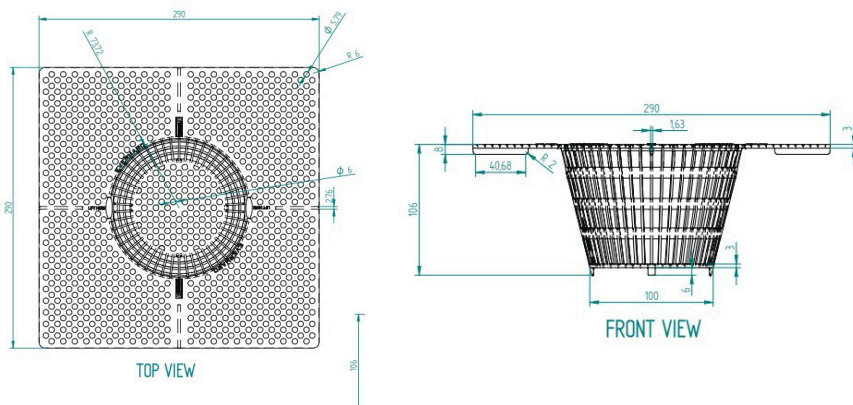

SERIES 300 STORMWATER PIT LEAF BASKET

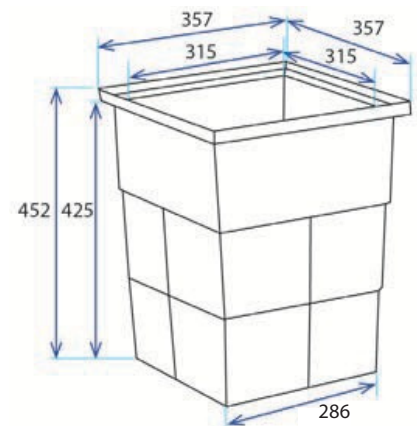

SERIES 300D STORMWATER PIT CASE