

## SEPTIC TANKS

Products covered in this spec sheet are as listed below:

Product	Code	Weight (kg)	Overall Size (mm)	Capacity	Category
2500L Polymer Septic Tank (No Partition)	87042	125kg	H: 1875 x Ø1880	2500L	Septic Tank
3000L Polymer Septic Tank	87001	125kg	H: 1875 x Ø1880	3000L	Septic Tank
3000L Polymer Septic Tank with Partition	87003	133kg	H: 1875 x Ø1880	3000L	Septic Tank
3000L Polymer Collection Well	87007	125kg	H: 1875 x Ø1880	3000L	Collection Well
4000L Polymer Septic Tank	87210	201kg	H: 2335 x Ø1880	4000L	Septic Tank
Septic Tank Riser (300mm)	87020N	77kg	Ø1860 x H: 910		Accessory
Polymer Tank Lid with Access Cover	87026C	28.7kg	Ø1860 x H: 285		Accessory
Plastic Access Cover	87116	3.16kg	625 x 625 x 50		Accessory
Inlet/Outlet Pipe	87047	0.89kg	300 x 300 x 600		Component

### Material

### Suitable Applications

Tanks: Polymer  
Riser & Lid: Polymer  
Access Cover: Polymer  
Drainage Components: Polymer



LOW-HIGH RAINFALL



OUTDOOR AREAS



RETAINING WALL



LANDSCAPING

### Warranty

Tanks 15 Years

Polymer Accessories 5 Years

## Product Drawing

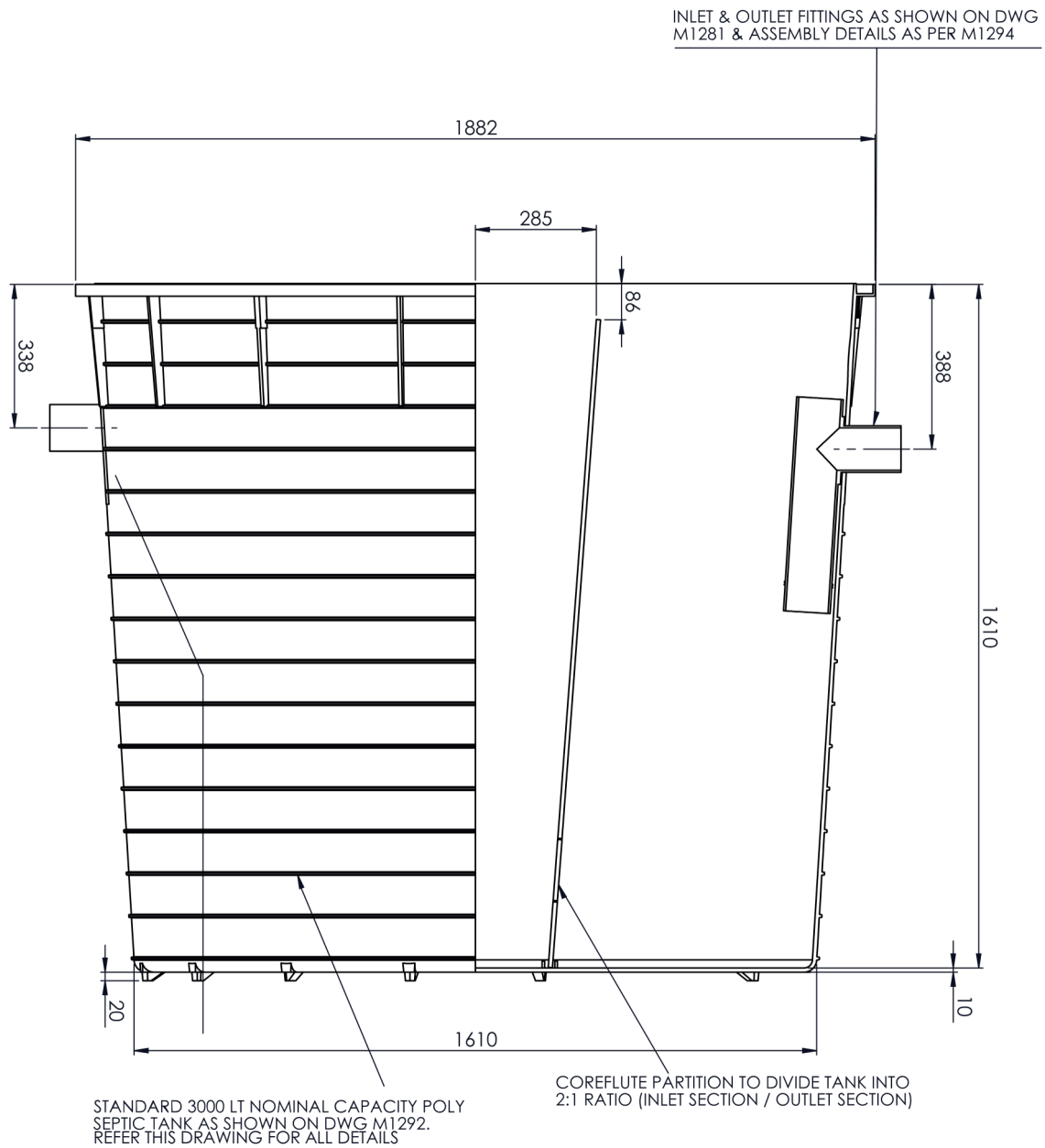

2500L SEPTIC TANK

## Product Drawing

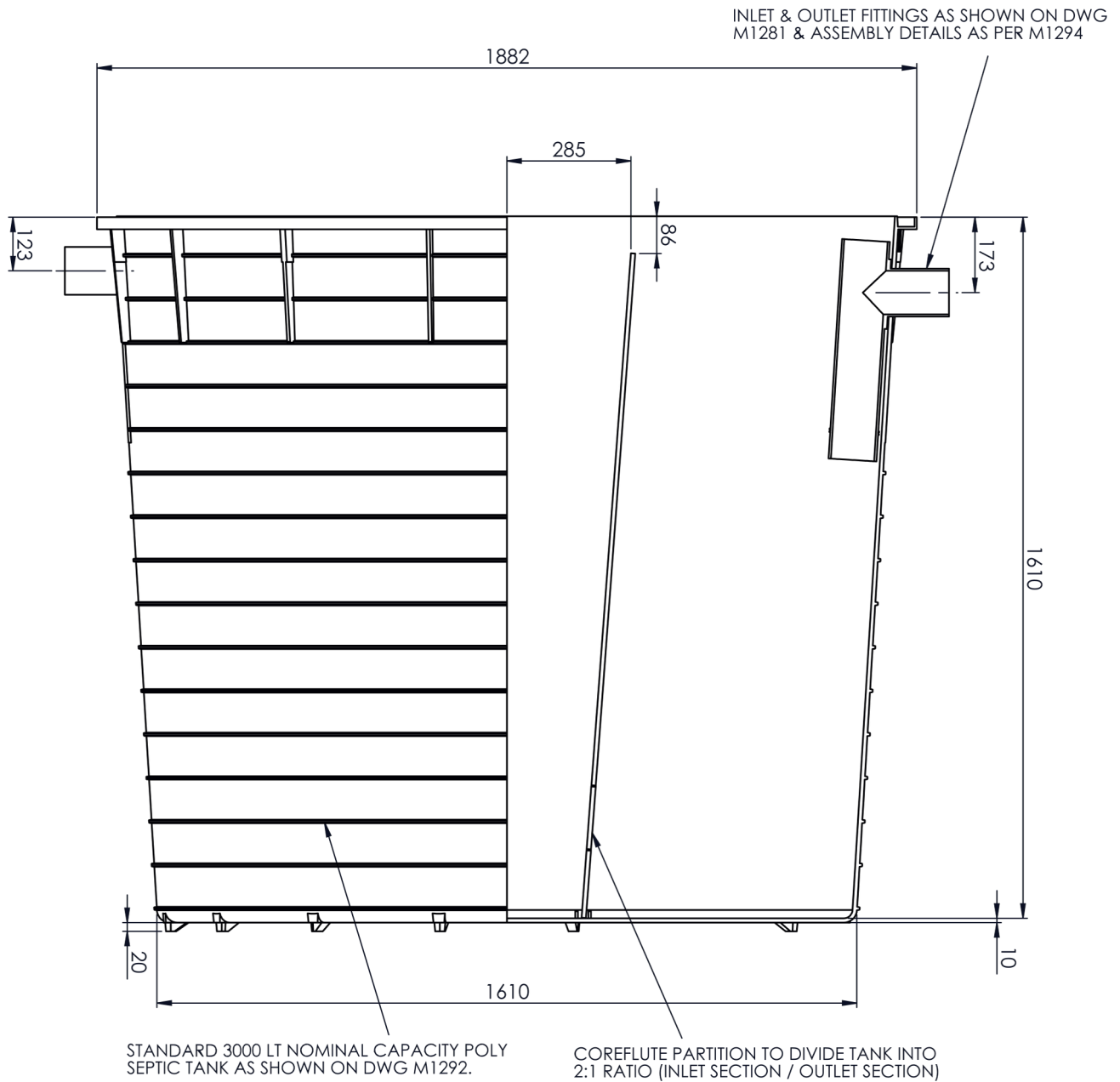

3000L SEPTIC TANK

## Product Drawing

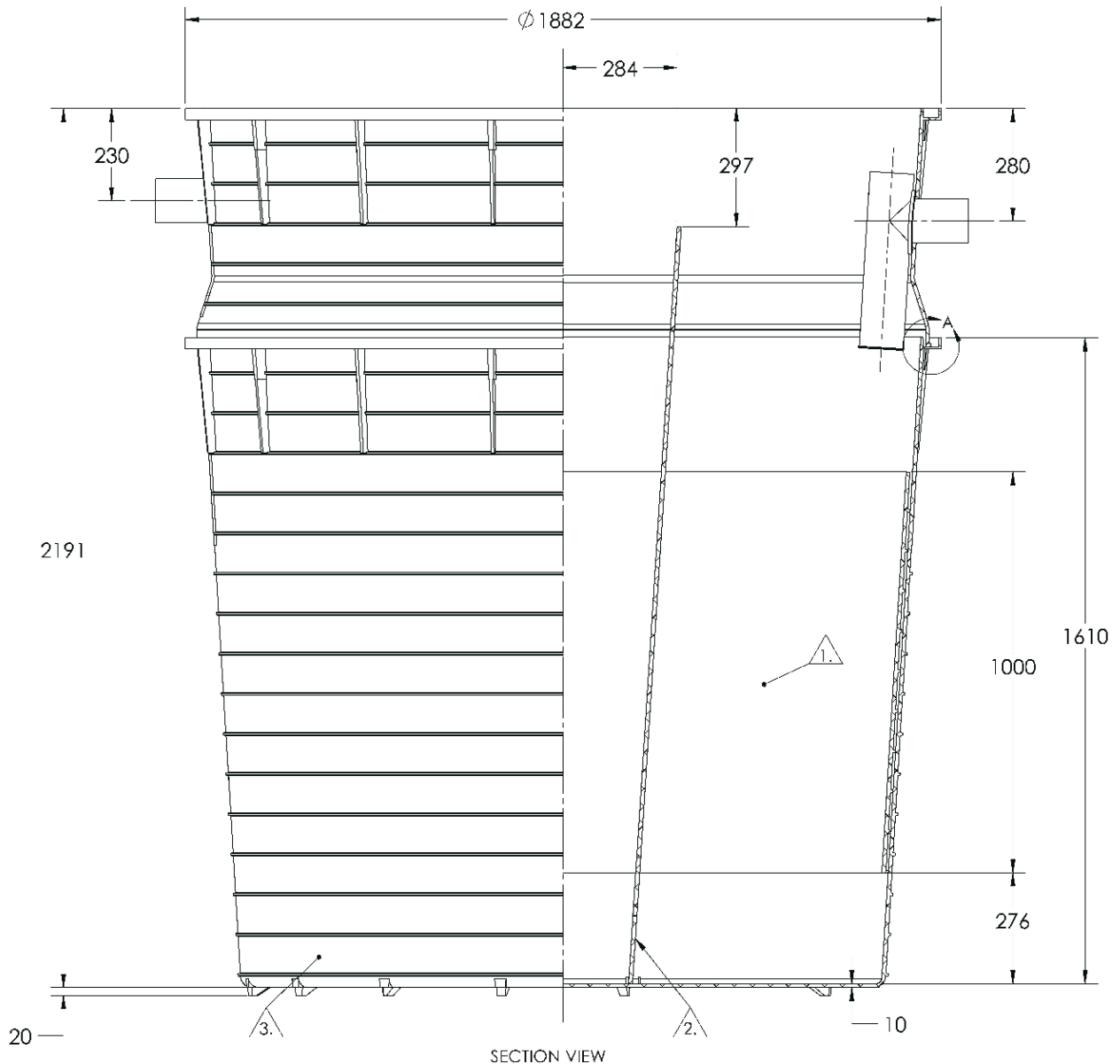

- 1. TANK REINFORCING SUPPLIED INSTALLED IN TANK AND PRESSED DOWN INTO POSITION SO THAT BOTTOM EDGE OF RING IS APPROX. 275mm ABOVE THE FLOOR LEVEL
- 2. CORFLUTE PARTITION TO DIVIDE TANK INTO 2:1 RATIO (INLET SECTION/OUTLET SECTION)
- 3. STANDARD 3000L NOMINAL CAPACITY POLY SEPTIC TANK AS SHOWN ON DWG P-TNK87010. REFER TO DRAWING FOR ALL DETAILS
- 4. TANK EXTENSION BELLED TO CORRECT DIAMETER USING HEAT BATH AND MANDREL
- 5. HOT AIR WELD TO SEAL JOINT
- 6. REAR OF JOINT SEALED BY HOT AIR WELDING

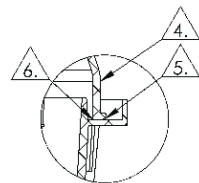

DETAIL A  
SCALE 1 : 5

ZONE	REV.	DESCRIPTION	DATE	APPROVED

### 4000L SEPTIC TANK