

PUMP WELL

Products covered in this spec sheet are as listed below:

Product	Code	Weight (kg)	Overall Size (mm)	Capacity	Category
250L / 450L / 600L Pump Well	82200E	42kg	H: 1200 x Ø1150	250L / 450L / 600L	Pump Well
1000L Polymer Pump Well	82202C	84kg*	H: 1820 x Ø1150	1000L	Pump Well
Universal Riser	82224	13kg	H: 704 x Ø804		Pump Well

Material

Pump Wells: PE Low/Medium Density
 Universal Riser: UV Stabilised polymer construction

Suitable Applications

- Receiving treated wastewater from septic tanks
- Pumped discharge to disposal areas
- Greywater, blackwater and all-waste transfer
- Residential and light commercial drainage systems
- High water table sites (with anchorage provisions)

Warranty

Polymer Pump Well 15 Years

Polymer Accessories 5 Years

Product Drawing

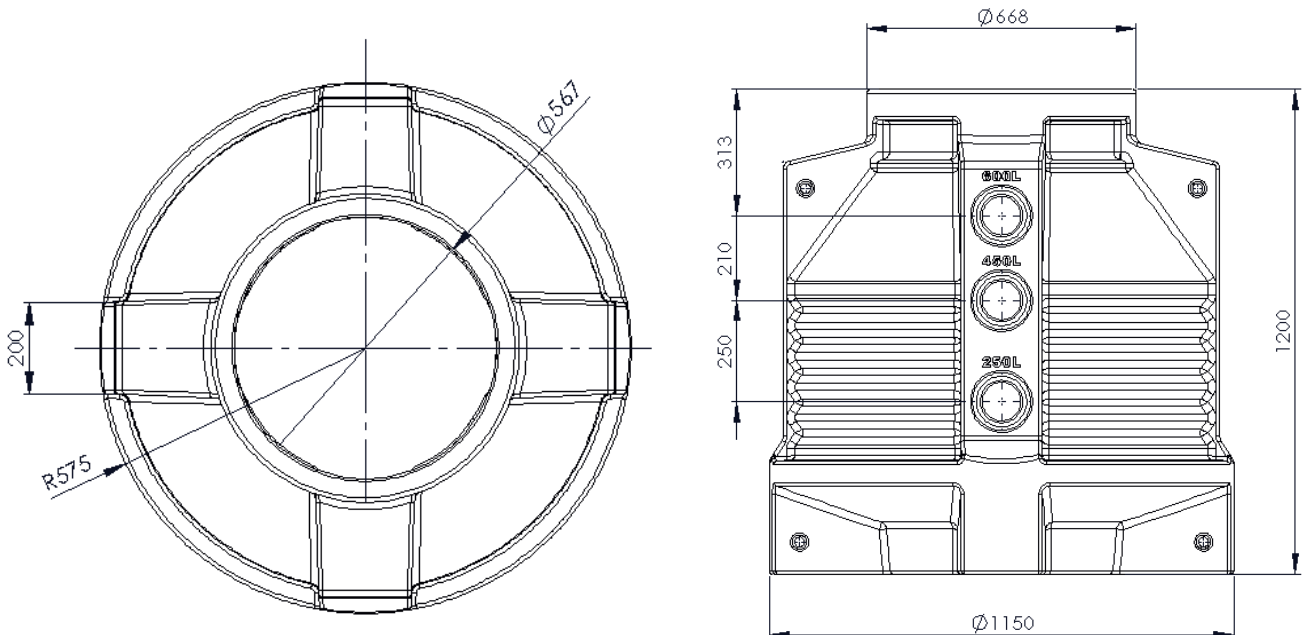

250L / 450L / 600L PUMP WELL

Product Drawing

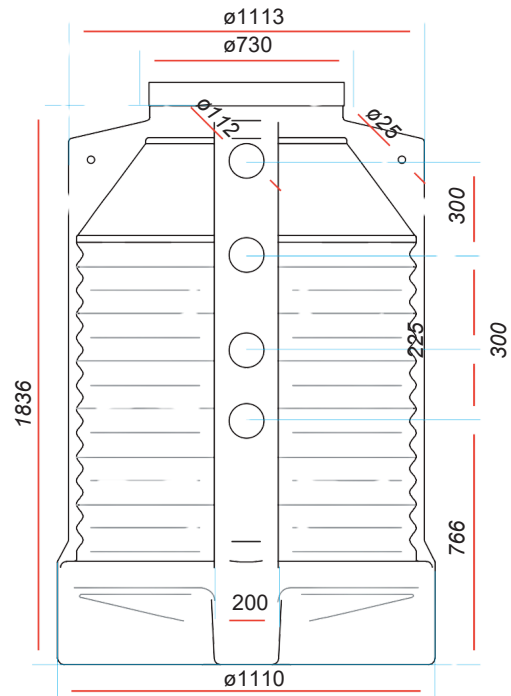
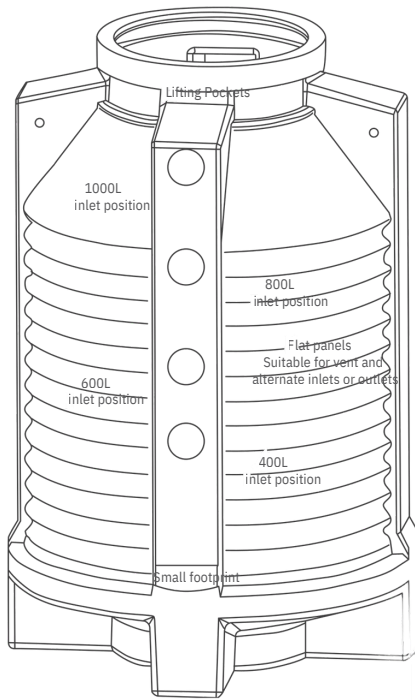

1000L PUMP WELL

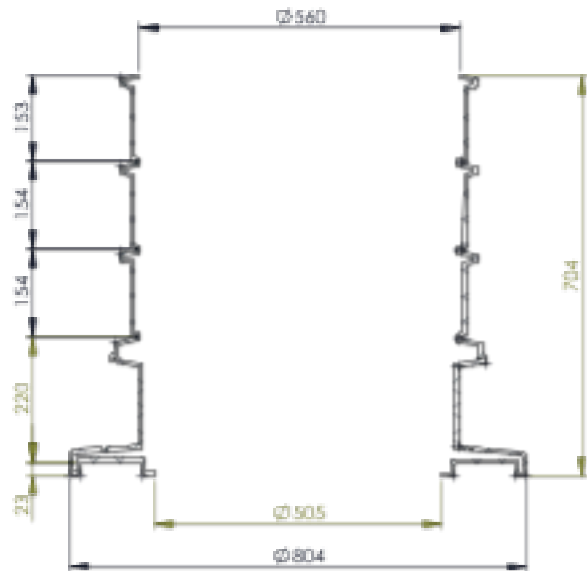
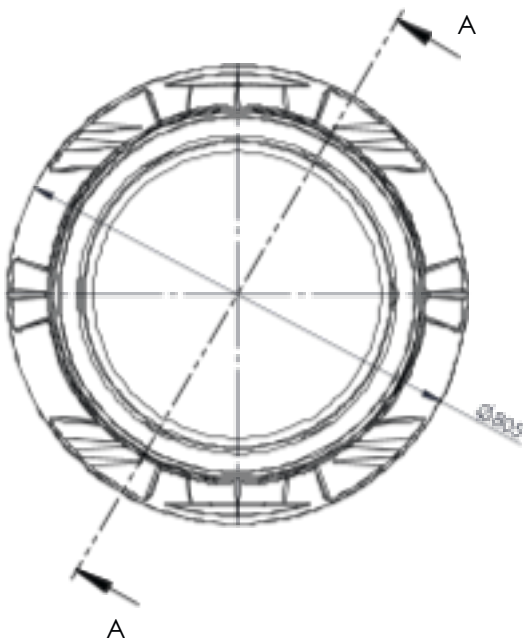

UNIVERSAL RISER