

# SPEC PACK BATHROOM COLLECTION

## SPEC SHEET



## NUGLEAM CONTOUR WALL FACED SUITE

### PRODUCT CODE:

75590

### FEATURES:

- / Rimless Pan
- / 450mm ambulant height pan
- / RH & LH bottom inlet and back inlet optional extra
- / Set out range 90mm-180mm included with pan
- / WELS 4 star 4.5L/3L dual flush
- / Optional pan connector 180-210mm (75533)

### OVERALL DIMENSIONS:

630 W x 880mm H

### WARRANTY:

- 10 years on cistern and pan
- 1 year on valves and seat

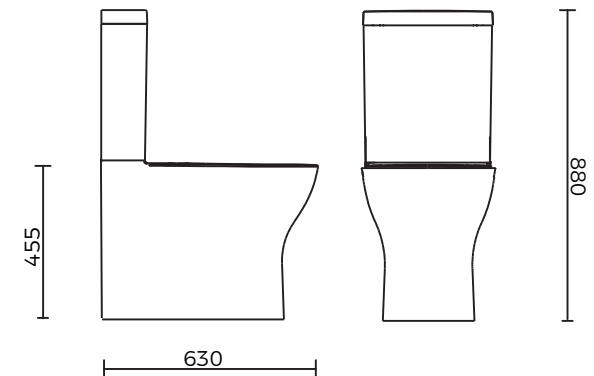

Disclaimer: All measurement are in millimetres and are solely for reference purposes. Colours have been reproduced with as much accuracy as possible. Any changes resulting from technical advance of design or colour may be made without prior notice. Tapware, accessories and appliances are for illustration purposes only. Further information on warranties is available at [www.everhard.com.au](http://www.everhard.com.au)

# SPEC PACK BATHROOM COLLECTION

## PRODUCT DRAWING

