

## 45L GREASE TRAP & RISER

Products covered in this spec sheet are as listed below:

Product	EI Code	Dimensions (mm)	Weight (kg)	Material	Category
45L Domestic Grease Trap	84010	H: 638 x Ø468	5kg approx	PP	Grease Trap
45L Grease Trap Riser – 144mm	84625	H: 144 x Ø466	3kg	PE	Riser
45L Grease Trap Riser – 300mm	84626	H: 300 x Ø466	3kg	PE	Riser

### Material

Grease Trap: Polypropylene (PP)  
Riser: Polyethylene (PE)

### Suitable Applications

- Domestic kitchens
- Laundry waste
- Bathroom wastewater
- Septic system pre-treatment
- Sewer discharge pre-treatment

### Warranty

Grease Trap 15 Years

Grease Trap Riser 15 Years

### Product Drawing

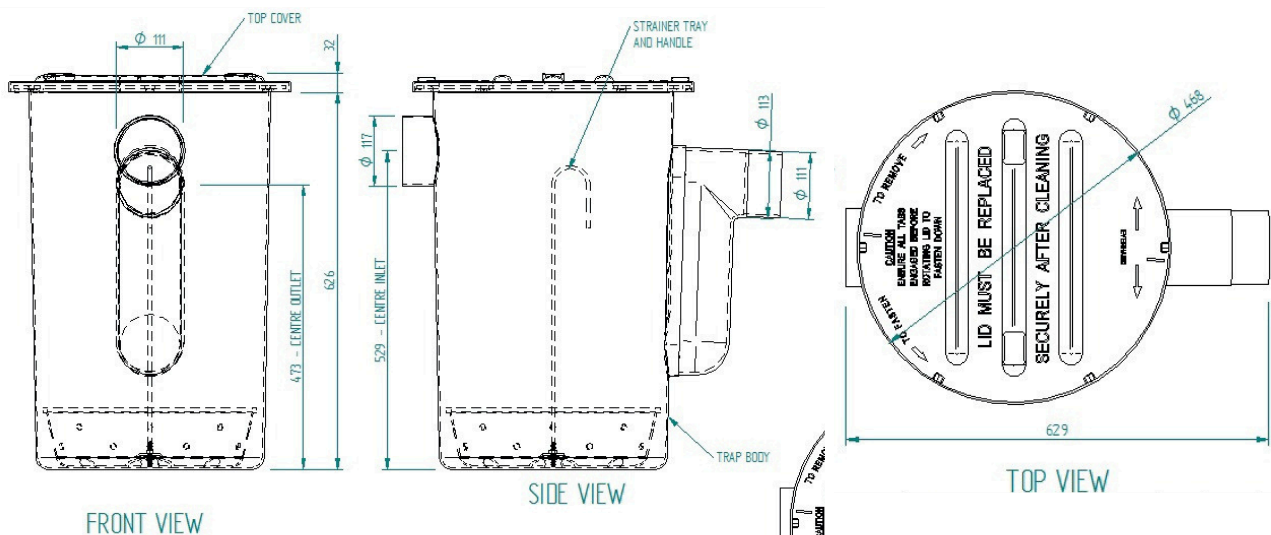

45L DOMESTIC GREASE TRAP

Disclaimer: All measurement are in millimetres and are solely for reference purposes. Colours have been reproduced with as much accuracy as possible. Any changes resulting from technical advance of design or colour may be made without prior notice. Further information on warranties is available at [www.everhard.com.au](http://www.everhard.com.au)

## Product Drawing

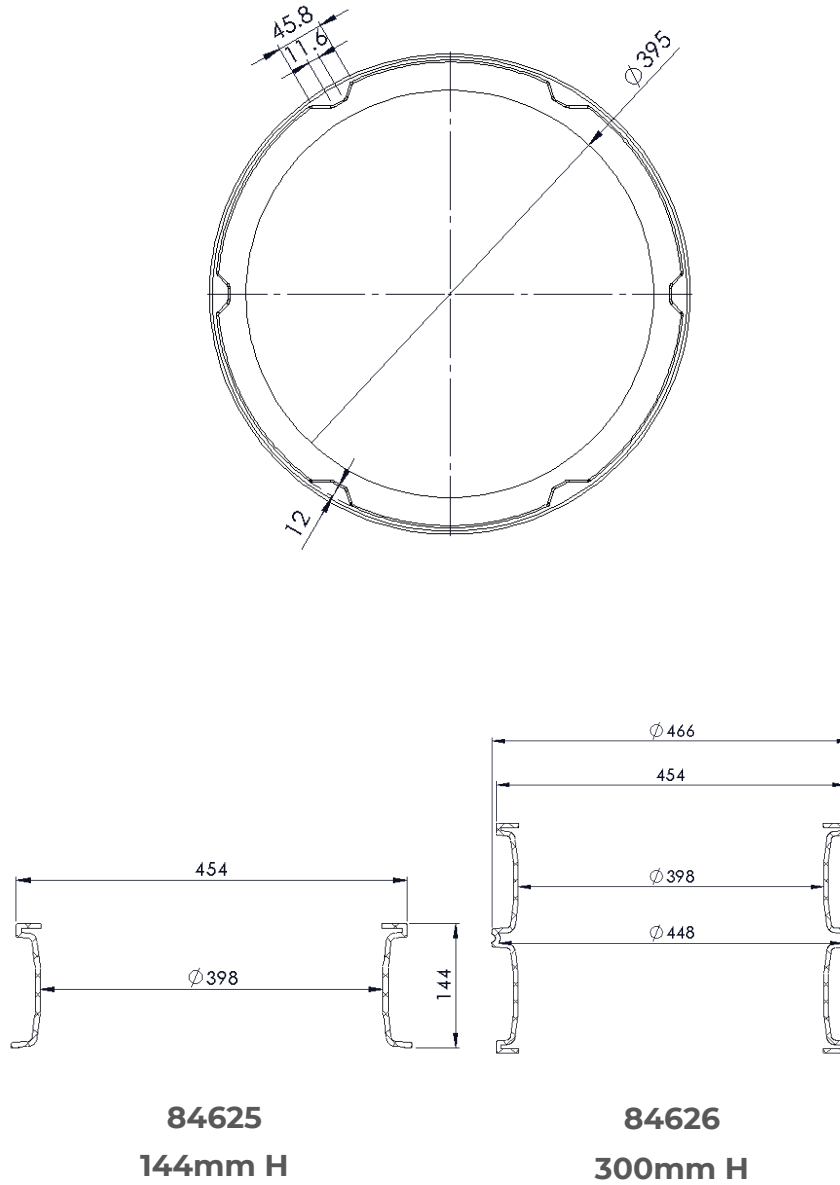

45L DOMESTIC GREASE TRAP RISER